

**STANDARD MATERIALS AND CONSTRUCTION**

**FRAME:** .081" thick (nominal) extruded aluminum, 6063-T52/T6 alloy.

**BLADE:** .081" thick (nominal) extruded aluminum, 6063-T52/T6 alloy.  
Blades approximately 3" on centers.

**LOUVER FACE:** All surfaces are flush, with jambs contained within the head and sill.

**SCREEN:** (When indicated.)

½" flattened aluminum (.051" thick),

-or- ½" sq. mesh, intermediate double-crimped aluminum wire, .063" dia.,

-or- ¼" mesh, .011" dia. aluminum wire, insect screen.

**FINISH:** Mill

**OPTIONS**

Finish - Baked Enamel, Kynar, Anodize

**NOTES**

- Nominal deductions will be made to the opening size given.
- Approximate shipping weight is 3.8 lbs./sq.ft.

**LOUVER SIZES**

Min Panel	Max Single Panel
12"W x 12"H	96"W x 60"H

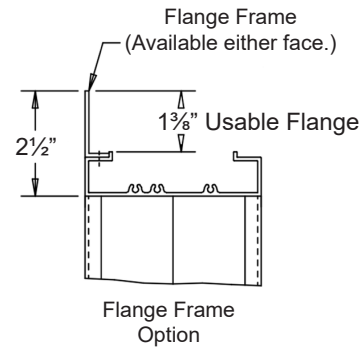
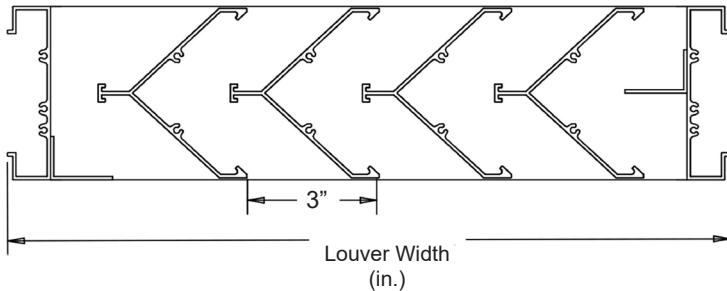
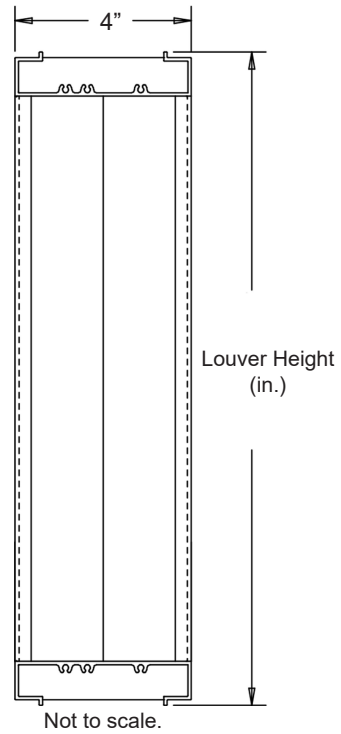

Item #	Qty	Width	Height	Width	Height	Mullion	Type	Location	Union Made
		Opening Size		Louver Size			Screens		
Arch. / Eng. :						EDR:	ECN:	Job:	
Contractor:									
Project:						Date:	DWN:	DWG:	



**PERFORMANCE DATA**

Pressure Drop: .35 in. w.g. at 1000 fpm (intake)  
 Free Area: 5.98 sq.ft. = 37.4% for 48"W x 48"H sample tested in accordance with AMCA Standard 500-L.  
 Beginning Point of Water Penetration: 984 fpm

Ratings do not include effects of a screen.

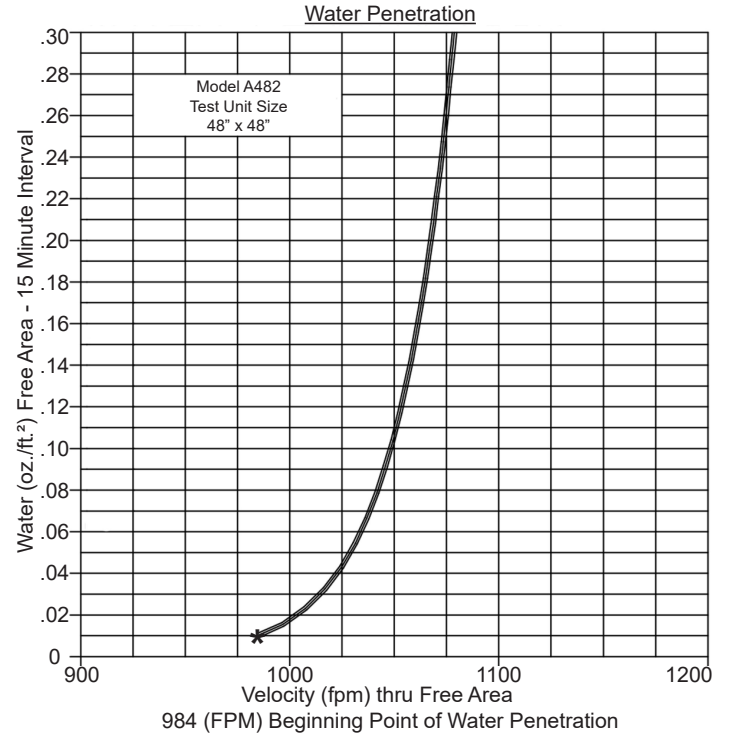
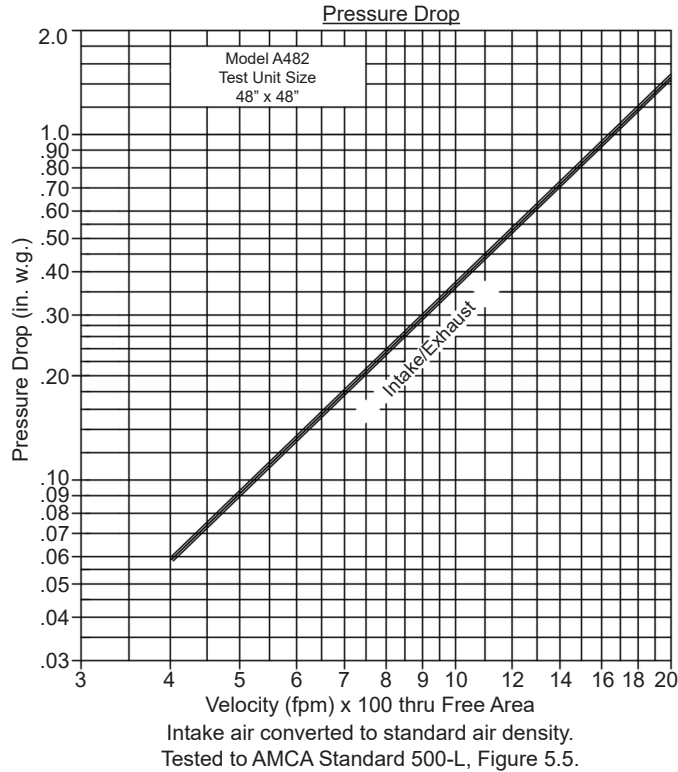

Free Area (sq.ft.)

		Width (in.)								
		12"	18"	24"	30"	36"	42"	48"	54"	60"
Height (in.)	12"	.26	.39	.52	.65	.77	.90	1.03	1.16	1.29
	24"	.67	1.01	1.34	1.68	2.01	2.35	2.68	3.02	3.35
	36"	1.08	1.62	2.17	2.71	3.25	3.79	4.33	4.87	5.41
	48"	1.50	2.24	2.99	3.74	4.49	5.23	5.98	6.73	7.48
	60"	1.91	2.86	3.81	4.77	5.72	6.68	7.63	8.58	9.54
	72"	2.32	3.48	4.64	5.80	6.96	8.12	9.28	10.44	11.60
	84"	2.73	4.10	5.46	6.83	8.20	9.56	10.93	12.29	13.66
	96"	3.14	4.72	6.29	7.86	9.43	11.00	12.58	14.15	15.72